



HCTB-3040
Thermoregulator
Operator's Manual



OMEGAnet™ On-Line Service http://www.omega.com	Internet e-mail info@omega.com
---	--

Servicing North America:

USA:
ISO 9001 Certified One Omega Drive, Box 4047
Stamford, CT 06907-0047
Tel: (203) 359-1660 FAX: (203) 359-7700
e-mail: info@omega.com

Canada:
976 Bergar
Laval (Quebec) H7L 5A1
Tel: (514) 856-6928 FAX: (514) 856-6886
e-mail: canada@omega.com

For immediate technical or application assistance:

USA and Canada: Sales Service: 1-800-826-6342 / 1-800-TC-OMEGASM
Customer Service: 1-800-622-2378 / 1-800-622-BESTSM
Engineering Service: 1-800-872-9436 / 1-800-USA-WHENSM
TELEX: 996404 EASYLINK: 62968934 CABLE: OMEGA

Mexico and Latin America: Tel: (95) 800-TC-OMEGASM FAX: (95) 203-359-7807
En Español: (203) 359-1660 ext: 2203 e-mail: espanol@omega.com

Servicing Europe:

Benelux: Postbus 8034, 1180 LA Amstelveen, The Netherlands
Tel: (31) 20 6418405 FAX: (31) 20 6434643
Toll Free in Benelux: 06 0993344
e-mail: nl@omega.com

Czech Republic: Ostravska 767, 733 01 Karvina
Tel: 42 (69) 6311899 FAX: 42 (69) 6311114
e-mail: czech@omega.com

France: 9, rue Denis Papin, 78190 Trappes
Tel: (33) 130-621-400 FAX: (33) 130-699-120
Toll Free in France: 0800-4-06342
e-mail: france@omega.com

Germany/Austria: Daimlerstrasse 26, D-75392 Deckenpfronn, Germany
Tel: 49 (07056) 3017 FAX: 49 (07056) 8540
Toll Free in Germany: 0130 11 21 66
e-mail: germany@omega.com

United Kingdom: 25 Swannington Road, P.O. Box 7, Omega Drive,
ISO 9002 Certified Broughton Astley, Leicestershire, Irlam, Manchester,
LE9 6TU, England M44 5EX, England
Tel: 44 (1455) 285520 Tel: 44 (161) 777-6611
FAX: 44 (1455) 283912 FAX: 44 (161) 777-6622
Toll Free in England: 0800-488-488
e-mail: uk@omega.com

It is the policy of OMEGA to comply with all worldwide safety and EMC/EMI regulations that apply. OMEGA is constantly pursuing certification of its products to the European New Approach Directives. OMEGA will add the CE mark to every appropriate device upon certification.

The information contained in this document is believed to be correct but OMEGA Engineering, Inc. accepts no liability for any errors it contains, and reserves the right to alter specifications without notice.

WARNING: These products are not designed for use in, and should not be used for, patient connected applications.

CONTENTS

HCTB-3040 Operator's Manual	
	<i>page</i>
SAFETY and INSTALLATION	
CE Declaration of Conformity	3
English	4
Français	6
Deutsch	8
Español	10
THE HCTB-3040	
Unpacking	12
Constant Temperature Baths	12
Description	12
Set Up	13
SPECIFICATION	
HCTB-3040	18
Baths	19
OPERATION	
When you switch on the HCTB-3040	21
Front Panel controls	21
Setting the Operating Temperature	24
After Use	24
Setting the overtemperature cutout	25
RS232 Serial Interface	26
Sending Data to a PC	26
ADDITIONAL INFORMATION	
Operator maintenance	27



Declaration of Conformity

Omega Unit HCTB-3040 has been designed to comply with the following European Standards:

EN 50081-1:1992 Electromagnetic Compatibility; Generic emission standard.

EN 50082-1:1992 Electromagnetic Compatibility; Generic immunity standard (Performance criterion B).

EN 61010-1:1993 Safety requirements for electrical equipment for measurement, control and laboratory use.

EN 61010-2-010:1995 Particular requirements for laboratory equipment for the heating of materials.

I have made all reasonable enquiries regarding the unit stated and its conformance to the following EU directives.

Low Voltage directive, 73/23/EEC and amendment 93/68/EEC, and

EMC Directive 89/336/EEC and amendments 91/263/EEC 92/31/EEC and 93/68/EEC.

To the best of my knowledge and belief these units conforms to these directives.



This Declaration is controlled under an ISO 9001:1994 system certificated by BSI Quality Assurance, certificate number FM13585.

Introduction

Please read all the information in this booklet before using the unit.

Warning

HIGH TEMPERATURES ARE DANGEROUS: they can cause serious burns to operators and ignite combustible material.

Omega have taken great care in the design of these units to protect operators from hazards, but Operators should pay attention to the following points:

- USE CARE AND WEAR PROTECTIVE GLOVES TO PROTECT HANDS;
- DO NOT put hot objects on or near combustible objects;
- DO NOT operate the unit close to inflammable liquids or gases;
- DO NOT place any liquid directly in your unit;
- At all times USE COMMON SENSE.

Operator Safety

All Operators of Omega equipment must have available the relevant literature needed to ensure their safety.

It is important that only suitably trained personnel operate this equipment, in accordance with the instructions contained in this manual and with general safety standards and procedures. If the equipment is used in a manner not specified by Omega the protection provided by the equipment to the Operator may be impaired.

All Omega units have been designed to conform to international safety requirements and are fitted with an overtemperature cutout. On some models, the cutout is adjustable and should be set to suit the application. On all other models the cutout is preset to protect the unit.

If a safety problem should be encountered, switch off at the mains socket and remove the plug from the supply.

Installation



1. All Omega units are supplied with a power cable. This may be integral or plug-in.
2. Before connecting the mains supply, check the voltage against the rating plate. The rating plate is on the rear of the unit. Connect the mains cable to a suitable plug according to the table below.

Note that the unit must be earthed to ensure proper electrical safety.

Connections	220V-240V	110V-120V
Live	Brown	Black
Neutral	Blue	White
Earth	Green/yellow	Green

Note that units marked 230V on the rating plate work at 220V; units marked 120V work at 110V. In both cases, however, the heating rate will degrade by approximately 8%.

3. Plug the mains cable into the socket on the rear of the unit.
4. Place the unit on a suitable bench or flat workspace, or in a fume cupboard if required, ensuring that the air inlet vents are free from obstruction.
5. Note that the following symbols may be next to the indicator lamps on the front panel of the units and have the following meanings:

	:	the power indicator
	:	the heater indicator
	:	the overtemperature indicator

6. Symbols on or near the power switch of the unit have the following meanings:

I	:	mains switch On
O	:	mains switch Off

After use

When you have finished heating samples, remember that parts of the unit – the tubes, blocks and associated accessories – may be very hot. Take the precautions listed earlier.

Operator maintenance

NOTE: THAT THIS EQUIPMENT SHOULD ONLY BE DISMANTLED BY PROPERLY TRAINED PERSONNEL.

REMOVING THE PANELS EXPOSES POTENTIALLY LETHAL MAINS VOLTAGES.

THERE ARE NO OPERATOR MAINTAINABLE PARTS WITHIN THE EQUIPMENT.

In the unlikely event that you experience any problems with your unit which cannot easily be remedied, you should contact your supplier and return the unit if necessary. Please include any details of the fault observed and remember to return the unit in its original packing. Omega accept no responsibility for damage to units which are not properly packed for shipping: if in doubt, contact your supplier. See the Decontamination Certificate supplied with your unit.

1. Cleaning

Before cleaning your unit ALWAYS disconnect it from the power supply and allow it to cool below 50° C.

Your unit can be cleaned by wiping with a damp soapy cloth. Care should be exercised to prevent water from running inside the unit. Do not use abrasive cleaners.

2. Overtemperature cutout

In the event of no heater power, check the mains plug and lead. Repeated operation of the cutout indicates a serious fault: you may need to return the unit to your supplier for repair.

3. Fuses

Your unit is protected by one or two fuses. These should only be changed by suitably qualified personnel.

If the fuses blow persistently, a serious fault is indicated and you may need to return the unit to your supplier for repair.

Introduction

Veuillez lire attentivement toutes les instructions de ce document avant d'utiliser l'appareil.

Avertissement

DANGER DE TEMPERATURES ELEVEES : les opérateurs peuvent subir de graves brûlures et les matériaux combustibles risquent de prendre feu.

Omega a apporté un soin tout particulier à la conception de ces appareils de façon à assurer une protection maximale des opérateurs, mais il est recommandé aux utilisateurs de porter une attention spéciale aux points suivants :

- PROCÉDER AVEC SOIN ET PORTER DES GANTS POUR SE PROTÉGER LES MAINS.
- NE PAS poser d'objets chauds sur ou près de matériaux combustibles.
- NE PAS utiliser l'appareil à proximité de liquides ou de gaz inflammables.
- NE PAS verser de liquide directement dans l'appareil.
- FAIRE TOUJOURS PREUVE DE BON SENS.

Sécurité de l'opérateur

Tous les utilisateurs de produits Omega doivent avoir pris connaissance des manuels et instructions nécessaires à la garantie de leur sécurité.

Important : cet appareil doit impérativement être manipulé par un personnel qualifié et utilisé selon les instructions données dans ce document, en accord avec les normes et procédures de sécurité générales. Dans le cas où cet appareil ne serait pas utilisé selon les consignes précisées par Omega, la protection pour l'utilisateur ne serait alors plus garantie.

Tous les appareils Omega sont conçus pour répondre aux normes de sécurité internationales et sont dotés d'un coupe-circuit en cas d'excès de température. Sur certains modèles, ce coupe-circuit est réglable pour s'adapter à l'application désirée. Sur d'autres modèles, il est pré-réglé en usine pour assurer la protection de l'appareil.

Dans le cas d'un problème de sécurité, coupez l'alimentation électrique au niveau de la prise murale et enlevez la prise connectée à l'appareil.

Installation



1. Tous les appareils Omega sont livrés avec un câble d'alimentation qui peut être intégré à l'appareil ou à raccorder.
2. Avant de brancher l'appareil, vérifiez la tension requise indiquée sur la plaque d'identification. Raccordez le câble électrique à la prise appropriée en vous reportant au tableau ci-dessous. Il est important que l'appareil soit relié à la terre pour assurer la protection électrique requise.

Connexions	220V-240 V	110V-120 V
Phase	marron	noir
Neutre	bleu	blanc
Terre	vert/jaune	vert

Le fusible à l'intérieur de l'appareil est destiné à assurer la protection de l'appareil et de l'opérateur.

Remarque : les appareils dont la plaque indique 230 V peuvent fonctionner sur 220 V, et ceux dont la plaque indique 120 V peuvent fonctionner sur 110 V. Dans les deux cas cependant, la capacité de chauffage diminuera d'environ 8 %. La plaque d'identification se trouve à l'arrière de l'appareil.

3. Raccordez le câble d'alimentation à la prise située à l'arrière de l'appareil.
4. Placez l'appareil sur un plan de travail ou surface plane, ou le cas échéant, dans une hotte d'aspiration, en s'assurant que les trous d'aération ne soient pas obstrués.
5. Les symboles ci-dessous situés à côté des témoins lumineux sur la face avant de l'appareil ont la signification suivante :

	~	: témoin d'alimentation
	⚡	: témoin de chauffage
	⚠	: témoin d'excès de température

6. Les symboles situés sur ou à côté de l'interrupteur de l'appareil ont la signification suivante :

- I : arrêt
- O : marche

Après utilisation

Lorsque vous avez fini de chauffer les échantillons, n'oubliez pas que certaines parties de l'appareil - les éprouvettes, leurs supports et autres accessoires - risquent d'être très chaudes. Il est donc recommandé de toujours prendre les précautions citées plus haut.

Entretien utilisateur

IMPORTANT : CET APPAREIL NE PEUT ETRE DEMONTE QUE PAR DU PERSONNEL QUALIFIE. LORSQUE LES PANNEAUX SONT DEMONTES, L'OPERATEUR EST EXPOSE A DES TENSIONS QUI PEUVENT ETRE MORTELLES. CET APPAREIL NE CONTIENT AUCUN ELEMENT QUI DEMANDE UN ENTRETIEN DE LA PART DE L'UTILISATEUR.

Dans le cas peu probable où votre appareil présente un défaut de fonctionnement auquel il est difficile de remédier, il est alors préférable de contacter votre fournisseur et, le cas échéant, de renvoyer le matériel. Veuillez inclure une description détaillée du problème constaté et retourner l'appareil dans son emballage d'origine. Omega ne sera pas tenu responsable des dommages subis par tout appareil dont l'emballage est inadéquat pour le transport. Pour plus de sûreté, contactez votre fournisseur. Voir le certificat de décontamination livré avec le produit.

1. Nettoyage

Avant de nettoyer l'appareil, assurez-vous TOUJOURS que le câble d'alimentation est déconnecté et laissez la température redescendre en dessous de 50 °C.

Utilisez un chiffon imprégné d'eau savonneuse pour nettoyer l'appareil. Veillez à ne pas introduire d'eau dans l'appareil. N'utilisez pas de produits abrasifs.

2. Coupe-circuit d'excès de température

- En l'absence de puissance de chauffe, vérifiez la prise et le câble d'alimentation puis réglez la commande du coupe-circuit (si votre appareil est doté de ce mécanisme).
- Si la sécurité se déclenche trop souvent, il s'agit d'un problème plus sérieux. Nous vous conseillons dans ce cas de prendre contact avec votre fournisseur pour réparation.

3. Fusibles

La protection de l'appareil est assurée par un ou deux fusibles dont le remplacement ne peut être effectué que par un personnel qualifié.

Si les fusibles sautent sans arrêt, il s'agit d'un problème sérieux. Nous vous conseillons dans ce cas de prendre contact avec votre fournisseur pour réparation.

Einleitung

Bitte lesen Sie diese Bedienungsanleitung komplett bevor Sie dieses Gerät benutzen.

Warnung

HOHE TEMPERATUREN SIND GEFÄHRLICH: sie können dem Bediener ernsthafte Verletzungen zufügen und brennbare Materialien können sich leicht entzünden.

Omega hat bei der Konstruktion dieses Gerätes sehr darauf geachtet, daß der Bediener vor Gefahren geschützt ist. Dennoch sollten Sie auf die folgenden Punkte achten:

- SEIEN SIE VORSICHTIG UND TRAGEN SIE SCHUTZHANDSCHUHE
- Legen Sie heiße Gegenstände NICHT auf oder in die Nähe von leicht brennbaren Materialien; vermeiden Sie Arbeiten in der Nähe von leicht entzündbaren Flüssigkeiten oder Gasen.
- Bringen sie KEINE Flüssigkeiten direkt in Ihr Gerät.
- Benutzen Sie immer den normalen Menschenverstand

Sicherheit des Anwenders



Alle Benutzer von Omega Geräten müssen Zugang zu der entsprechenden Literatur haben, um ihre Sicherheit zu gewähren. Es ist wichtig, daß diese Geräte nur von entsprechend geschultem Personal betrieben werden, das die in dieser Gebrauchsanweisung enthaltenen Maßnahmen und allgemeine Sicherheitsbestimmungen und -vorkehrungen beachtet. Wenn das Gerät anders eingesetzt wird als vom Hersteller empfohlen, kann dies die persönliche Sicherheit des Anwenders beeinträchtigen. Die Geräte von Omega entsprechen den internationalen Sicherheitsbestimmungen und sind mit einem automatischen Übertemperaturabschalter ausgestattet. Bei einigen Modellen ist der Übertemperaturabschalter verstellbar und sollte je nach Anwendung entsprechend eingestellt werden. Bei allen anderen Modellen ist der Temperaturschutz voreingestellt um Schäden am Gerät zu vermeiden. Wenn ein Sicherheitsproblem auftreten sollte, muß das Gerät ausgeschaltet und vom Stromnetz getrennt werden.

Installation

1. Alle Omega Geräte werden mit einem Stromanschlußkabel geliefert. Dieses ist entweder fest mit dem Gerät verbunden oder zum Einstecken.
2. Vergleichen Sie, ob die Spannung Ihrer Stromversorgung mit den Angaben auf dem Typenschild des Gerätes übereinstimmen. Verbinden Sie das Stromanschlußkabel mit einer geeigneten Stromversorgung gemäß der nächstehenden Tabelle. **Achtung:** Das Gerät muß geerdet sein, um die elektrische Sicherheit zu gewährleisten!

Verbindungen	220V-240V	110V-120V
Stromführend	Braun	Schwarz
Neutral	Blau	Weiß
Erde	Grün/Gelb	Grün

Geräte, die für 230 Volt ausgelegt sind, können auch bei 220 Volt arbeiten, Geräte für 120 Volt auch bei 110 Volt. In beiden Fällen verringert sich die Aufheizrate um ca. 8%. Das Typenschild befindet sich hinten am Gerät.

3. Stecken Sie das Stromkabel in die vorgesehene Buchse hinten am Gerät.
4. Stellen Sie das Gerät auf eine ebene Arbeitsfläche bzw. (falls erforderlich) unter einen Laborabzug. Beachten Sie, daß die Entlüftungsrillen immer frei zugänglich sind.
5. Wenn die Anzeigenlampchen an der Vorderseite leuchten, hat dies folgende Bedeutung:
 - ~ : Gerät ist eingeschaltet
 -  : Gerät heizt
 -  : Übertemperaturschutz ist ausgelöst
6. Die Symbole auf oder neben dem EIN/AUS-Schalter an der Geräterückseite bedeuten:
 - I : An
 - O : Aus

Nach dem Gebrauch

Vergessen Sie nicht, daß Teile des Gerätes (die Gefäße, die Blöcke und andere Zubehörteile) nach dem Erhitzen von Proben noch sehr heiß sein können. Bitte beachten Sie die oben genannten Vorsichtsmaßnahmen.

Wartung durch den Bediener

BEACHTEN SIE, DASS DIESES GERÄT NUR VON TECHNISCHEN FACHKRÄFTEN GEÖFFNET UND DEMONTIERT WERDEN DARF. DURCH ENTFERNEN DES GERÄUSES ODER GEHÄUSETEILEN SIND BAUTEILE MIT LEBENGEFÄHRLICHEN SPANNUNGEN FREI ZUGÄNGLICH. IM INNERN DES GERÄTES BEFINDEN SICH KEINE TEILE, DIE VOM ANWENDER GEWARTET WERDEN MÜSSEN.

Falls Ihr Gerät nicht ordnungsgemäß arbeitet, wenden Sie sich an Ihren Lieferanten oder senden Sie das Gerät wenn nötig zurück. Fügen Sie eine genaue Beschreibung des Defektes bei. Verpacken Sie das Gerät möglichst im Originalkarton. Bitte beachten Sie, daß Omega und thermo-DUX keine Haftung bei Transportschäden aufgrund unzureichender Verpackung übernehmen. Setzen Sie sich im Zweifelsfall mit Ihrem Lieferanten in Verbindung. Bitte beachten Sie die Entgiftungsbescheinigung, die Sie mit dem Gerät erhalten haben.

1. Reinigen

Bevor Sie Ihr Gerät reinigen, sollten Sie

- zuerst den Netzstecker ziehen
- das Gerät unter 50°C abkühlen lassen.

Ein feuchtes Tuch mit Seifenlösung reinigt Ihr Gerät am besten. Achten Sie darauf, daß kein Wasser in das Gerät gelangt. Verwenden Sie keine Scheuermittel.

2. Übertemperaturabschalter

- Der Übertemperaturschutz ist ein empfindliches mechanisches Teil. Schon eine Erschütterung kann diesen auslösen.
- Falls die Heizung nicht funktioniert, überprüfen Sie zuerst Netzstecker und Kabel. Setzen Sie dann den Übertemperaturabschalter (an der Rückseite des Gerätes) wieder zurück, indem Sie den roten Knopf einmal bis zum Anschlag drücken.
- Wenn der Übertemperaturabschalter wiederholt auslöst, liegt ein größerer Defekt vor. Das Gerät muß zur Reparatur an Ihren Lieferanten eingeschickt werden.

3. Sicherungen

Die Stromzuleitung ist durch ein oder zwei Sicherungen geschützt. Diese sollten nur durch qualifiziertes Fachpersonal ausgetauscht werden. Wenn die Sicherung wiederholt durchbrennt, liegt ein größerer Defekt vor. Das Gerät muß zur Reparatur an Ihren Lieferanten eingeschickt werden.

Introducción

Le rogamos lea cuidadosamente la información contenida en este folleto antes de manipular el aparato.

Aviso

LAS TEMPERATURAS ELEVADAS SON PELIGROSAS: pueden causarle graves quemaduras y provocar fuego en materiales combustibles.

Omega ha puesto gran cuidado en el diseño de estos aparatos para proteger al usuario de cualquier peligro; aún así se deberá prestar atención a los siguientes puntos:

- EXTREME LAS PRECAUCIONES Y UTILICE GUANTES PARA PROTEGERSE LAS MANOS;
- NO coloque objetos calientes encima o cerca de objetos combustibles;
- NO maneje el aparato cerca de líquidos inflamables o gases;
- NO introduzca ningún líquido directamente en el aparato;
- UTILICE EL SENTIDO COMUN en todo momento.

Seguridad del usuario

Todos los usuarios de equipos Omega deben disponer de la información necesaria para asegurar su seguridad.

De acuerdo con las instrucciones contenidas en este manual y con las normas y procedimientos generales de seguridad, es muy importante que sólo personal debidamente capacitado opere estos aparatos. De no ser así, la protección que el equipo le proporciona al usuario puede verse reducida.

Todos los equipos Omega han sido diseñados para cumplir con los requisitos internacionales de seguridad y traen incorporados un sistema de desconexión en caso de sobretemperatura. En algunos modelos el sistema de desconexión es variable, lo que le permite elegir la temperatura según sus necesidades. En otros, el sistema de desconexión viene ya ajustado para evitar daños en el equipo.

En caso de que surgiera un problema de seguridad, desconecte el equipo de la red.



Instalación

1. Todos los aparatos Omega se suministran con un cable de alimentación. Puede ser fijo o independiente del aparato.
2. Antes de conectarlo, compruebe que el voltaje corresponde al de la placa indicadora. Conecte el cable de alimentación a un enchufe adecuado según la tabla expuesta a continuación. El equipo debe estar conectado a tierra para garantizar la seguridad eléctrica.

<i>Conexiones</i>	220V-240V	110V-120V
Linea	Marrón	Negro
Neutro	Azul	Blanco
Tierra	Verde/amarillo	Verde

Asegúrese de que los equipos marcados 230V en la placa indicadora funcionan a 220V y de que los equipos marcados 120V funcionan a 110V. No obstante, en ambos casos la velocidad de calentamiento se verá reducida en un 8% aproximadamente. La placa indicadora está situada en la parte posterior del equipo.

3. Conecte el cable a la toma de tensión en la parte posterior del equipo.
4. Sitúe el aparato en un lugar apropiado tal como una superficie de trabajo plana, o si fuera necesario incluso en una campana con extractor de humos, asegurándose de que las entradas de aire no queden obstruidas.
5. Los símbolos, que pueden aparecer junto a las luces indicadoras en el panel frontal del equipo, tienen los siguientes significados:

-  ~ : Indicador de potencia
-  : Indicador del calor
-  : Indicador de sobretemperatura

6. Los símbolos que se encuentran en o cerca del interruptor de alimentación tienen los siguientes significados:

I : Interruptor principal encendido
O : Interruptor principal apagado

Después de su uso

Cuando haya finalizado el calentamiento de muestras, recuerde que las piezas del equipo, tales como tubos, bloques y demás accesorios, pueden estar muy calientes. Tome las precauciones mencionadas anteriormente.

Mantenimiento

ESTE APARATO DEBE SER DESMONTADO SOLO Y EXCLUSIVAMENTE POR PERSONAL DEBIDAMENTE CAPACITADO.

EL RETIRAR LOS PANELES SUPONE DEJAR AL DESCUBIERTO TENSION DE LA RED PELIGROSA. EL EQUIPO NO CONSTA DE NINGUNA PIEZA DE CUYO MANTENIMIENTO SE PUEDA ENCARGAR EL USUARIO.

En el caso improbable de que experimentara algún problema con su aparato que no pudiera resolver con facilidad, debería ponerse en contacto con su proveedor y devolverlo si fuera necesario. Indique de forma detallada todos los defectos que haya notado y devuelva el equipo en su embalaje original. Omega no aceptará responsabilidad alguna por daños causados en equipos que no estuvieran debidamente embalados para su envío; si tuviera alguna duda, póngase en contacto con su proveedor. Sirvase consultar el Certificado de Descontaminación suministrado con su aparato.

1. Limpieza

Antes de limpiar su aparato, desconéctelo SIEMPRE de la fuente de alimentación y permita que se enfrie por debajo de los 50°C.

Este aparato se puede limpiar pasándole un paño húmedo enjabonado. Hágalo con cuidado para evitar que caiga agua dentro del mismo. No utilice limpiadores abrasivos.

2. Desconexión en caso de sobretemperaturas

El sistema de desconexión en caso de sobretemperaturas es un dispositivo mecánico sensible (una sacudida mecánica podría desconectarlo).

- Si el calefactor no recibiera alimentación, compruebe el enchufe y el cable de la toma de corriente; a continuación vuelva a ajustar el control del dispositivo (si su equipo lo lleva montado).
- Una desconexión repetida indicaría una avería grave; puede que tenga que devolverle el aparato a su proveedor para su reparación.

3. Fusibles

Su aparato está protegido por uno o dos fusibles. Sólo deben cambiarlos personal debidamente capacitado.

Si los fusibles se fundieran repetidamente, esto indicaría una avería grave y puede que tuviera que devolverle el aparato a su proveedor para su reparación.

THE HCTB-3040

Make sure you have read this manual carefully before you use the thermoregulator.

Constant Temperature Baths

Omega supply a range of liquid baths from 8 to 48 litre on which you can fit the HCTB-3040 thermoregulator. The B-8, B-12, B-18, and B-26 bath inner containers are manufactured from stainless steel for maximum corrosion resistance and are deep drawn with large easy clean corner radii. The B-48 inner is also manufactured from stainless steel but is of welded construction.

Description

The thermoregulator is designed to fit all standard laboratory baths, especially Omega baths. It will heat, circulate and safely control the temperature of the liquid in the bath within precise limits.

The HCTB-3040 will control the temperature of the liquid in a suitable bath within the range -40°C to 250°C (see the specification for details). However, temperatures from -40°C to "25°C above ambient" (35°C for Calibration Baths) require an additional cooling system.

The instrument consists of the following main parts:

- A base moulding in PPS plastic.
- Pump support legs in Victrex Peek.
- A pump assembly in stainless steel which can circulate liquid externally under pressure or suction via its support tubes.
- A heater assembly in Stainless Steel.
- A base plate made from stainless steel to which are mounted the motor, overtemperature cut-out, mains switch, fuse holder and PCB assembly.
- A cover made from Noryl plastic to which is fitted the digital controls.

The bath temperature is monitored and controlled by a PRT in conjunction with a 3 term controller.

Overtemperature protection is provided by means of an adjustable cutout which also activates an audible alarm. The pump motor and the transformer are also fitted with thermal fuses.

A portable clamp or a bridge piece are available as alternative ways of fixing the thermoregulator to the bath.

Set Up

- 1 There are two modes of operation for the pump; circulation internal to the bath; circulation external to the bath.

For internal circulation the blanking caps on the top of the outlet and return pipes should be securely in place. They screw on and, for safety, they may be tight.

For external circulation the blanking caps need to be removed. With the blanking cap removed, and an external circuit set up, the liquid will be split between internal flow and external flow.

- 2 **CAUTION: DO NOT SWITCH THE THERMOREGULATOR ON UNLESS EITHER THE BLANKING PLUGS ARE FITTED TO THE TOP OF THE PIPES or AN EXTERNAL CIRCUIT IS FULLY CONNECTED.**

IF YOU ARE PUMPING TO AND FROM A SECOND OPEN BATH A RESTRICTION MUST BE PUT ON THE PRESSURE SIDE OF THE PIPES. THE PRESSURE VOLUME IS GREATER THAN THE SUCTION VOLUME AND YOU COULD OVER-FILL THE SECOND BATH

- 3 Ensure that the bath is set up on a flat level surface.
- 4 Fit the unit securely to the bath using the correct bridge piece for the unit/ bath or a portable clamp, see the list of accessories. THE UNIT MUST ALWAYS BE MOUNTED WITH THE BACK AND THE SWITCH END OUTSIDE THE AREA OF THE BATH. This will reduce the infiltration of hot vapours into the cooling system of the thermoregulator. Ensure that at all times the air inlet and outlet remain clear of obstructions. Free circulation of air inside the unit is essential for proper cooling of the electronics and pump motor.

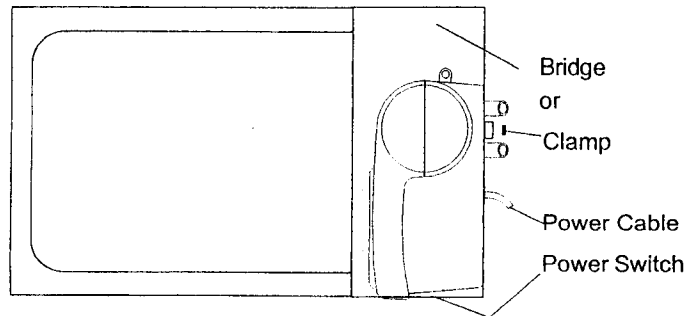

- 5 Use the M4 screw provided with the bridge kit to secure the bridge piece to the thermoregulator at the heater end of the thermoregulator, do not over tighten it. Thumb screw 2 secures both the unit and the bridge to the bath. Thumb screw 3 secures both the cover and the bridge to the bath. Thumb screw 4 is fitted at Omega and secures the cover to the bridge. A bung is provided to seal off the thermometer hole in the bridge piece if a thermometer is not used. It is necessary to fit this bung to reduce heat losses and prevent steam or other vapours getting to the thermoregulator.

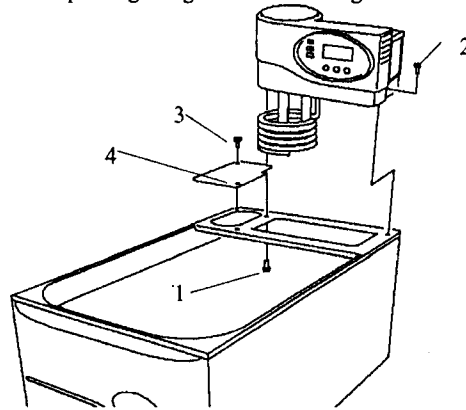

- 6 If you do not want to use a bridge piece to secure the unit to a bath then you must use a clamp. The clamp bracket fits between the pump legs in the slot provided. Slide the bracket into the slot and use the two screws in clamp kit to secure the clamp to the unit.

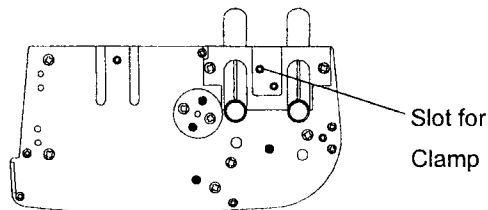

- 7 If the pump has been set correctly for external circulation, suitable hoses should be fitted to the outlet and return pipes. A suitable hose must be capable of withstanding both the temperature of operation and the liquid being used. Always securely clip the hoses in place.

Material	Allowable Temperature Range	Comments
PVC	10°C to 60°C (50°F to 140°F)	For water only
Silicone	-40°C to 200°C (-40°F to 362°F)	NOT for silicone oil
Viton	-20°C to 250°C (-4°F to 482°F)	

- 8 The cooling coil will give control for temperatures between 5°C above ambient and 5°C above the temperature of the water supply.

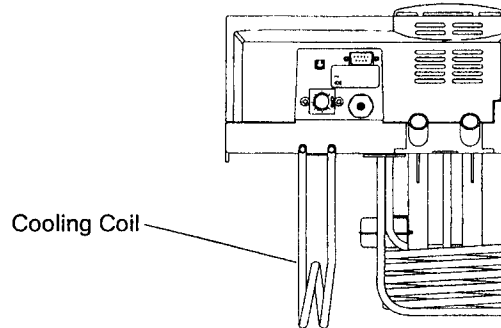

The cooling coil is fitted to the thermoregulator just below the overtemperature cutout reset button. Connect a hose from a tap to one end of the coil and from the other end of the coil to drain. Adjust the water flow to give the required cooling.

If you are using the thermoregulator on certain baths, for example the Omega Calibration Bath 7 litre, you will need to remove the cooling coil. Remove the screw which is used to fit the cooling coil to the base of the unit. Keep the cooling coil in a safe place in case you need to replace it.

- 9 For lower temperatures, a Dip Cooler such as an Omega RCTB-3050, RCTB-3060 or a Flow Cooler such as the RCTB-3070 or the RCTB-3080 is required. See the instruction Manuals for these units for connections and setup.

- 10 If a thermometer is to be used it may be fitted in the end of the top cover using the O-ring, supplied with the unit, between the two lugs. If a bridge is fitted it is necessary to remove the blanking plug.
- 11 Fill the bath to between the minimum and maximum levels stated in the specification.

If you are using oil at the highest temperatures, remember that they will expand as the temperature rises. Even if you fill the bath with oil to the minimum level, it may well reach the maximum level before the top temperature is reached. Take all precautions and monitor the level through the full range.

If water is used, demineralised water is preferred to reduce the formation of scale. If scale should form, use only mild de-scaling agents to remove it. DO NOT attempt to hammer, chip or scrape the deposits from the surface of the bath

- 12 Recommended liquids:

<i>Temperature</i>	<i>Liquid</i>
-40°C to 0°C	40% water 40% ethylene glycol 20% alcohol
-20°C to 30°C	50% water 50% ethylene glycol
5°C to 95°C	water, preferably de-ionised with neutral pH
10°C to 150°C	Dow Corning Silicone Oil 200 series *
10°C to 250°C	Dow Corning Silicone Oil 210H/100cs series *

* **Warning:** check gel life at top end of range.



Extraction may be necessary at high temperatures; always check the manufacturer's data and safety sheets before using any of the liquids.



In all cases the OVERTEMPERATURE CUT-OUT must be **set correctly** for the liquid being used and the temperature at which it is to operate



- 13 A bath that is fitted with a lid or insulating ball blanket gives the best operating conditions. A lid or ball blanket will prevent vapour loss, heat loss and give better temperature control. If an open bath is used above 80°C (ie where steam or other readily condensing vapours are present) the operation of the unit, particularly the digital display, may be affected.

Below about 80°C a cover becomes less important but will still give better temperature control.

- 14 The symbols next to the indicator lamps on the front panel of the thermoregulators have the following meanings:

  : the power indicator

  : the heater indicator

  : the overtemperature indicator

- 15 Symbols on the switch have the following meanings:

I : mains switch On

O : mains switch Off

Specification

The specification was achieved in an 8 litre bath with a ball blanket according to DIN 58966.

Operating temperature range		-40 to +250°C
Working temperature range		25°C above ambient (35°C for Calibration Baths) to 250°C
Temperature selection		Digital
Temperature display		Digital LED
Temperature stability		±0.005°C
Set point accuracy		±1°C
Method of control		3 Term
Temperature sensor		PRT
Nominal heater power	230V	1800W
	120V	1500W
	100V	1250W
Maximum watts density		6.2 W/cm ²
Pump capacity:	Pressure	Maximum flow 20 l/min
		Maximum pressure 250 mbar
	Suction	Maximum flow 15 l/min
		Maximum pressure 210 mbar
	Combined	Maximum pressure 450 mbar
Audible alarm for		Overtemperature
Cooling coil		As standard
Communications		RS232
Protection against hazards		IP30
Safety device classification		2
The HCTB-3040 has passed:		
EN 50081-1:1992		
Electromagnetic Compatibility		
emission standard.		
EN 50082-1:1992		
Electromagnetic Compatibility		
immunity standard		
(Performance criterion B).		

BATHS

Nominal Dimensions

Bath		B-8	B-12	B-18	B-26	B-48
<i>Overall</i>						
Length	A	265 mm	354 mm	530 mm	530 mm	559 mm
Width	B	325 mm	325 mm	325 mm	325 mm	365 mm
Height	C	172 mm	172 mm	172 mm	222 mm	296 mm
<i>Internal</i>						
Maximum Length	D	240 mm	329 mm	505 mm	505 mm	560 mm
Working Length	E	115 mm	205 mm	380 mm	380 mm	435 mm
Width	F	300 mm	300 mm	300 mm	300 mm	330 mm
Max. Working Depth	G	130 mm	130 mm	130 mm	180 mm	255 mm
Min. Working Depth	H	90 mm	90 mm	90 mm	140 mm	215 mm
Maximum Capacity		8 l	12.0 l	18.0 l	26.0 l	48.5 l
Minimum Capacity		6 l	8.4 l	13.2 l	20.5 l	42.5 l

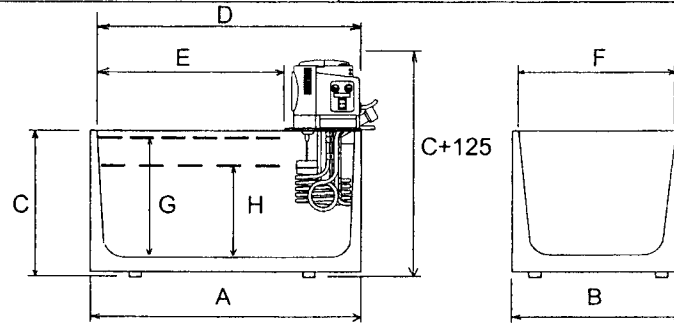

Working Environment

The HCTB-3040 units are designed to work safely under the following conditions:

Ambient temp. range 5°C to 40°C

Humidity Up to 95% relative humidity, non-condensing

Note: The control specifications quoted are for an ambient temperature range of 10°C to 30°C. The specification may deteriorate outside this range but the unit will still work safely.

Radio frequency interference tested and passed to EN50081-1.

Immunity Tested and passed to EN50082-1

OPERATION

- Ensure that either the outlet and return pipes have their caps on or an external system is properly set up.

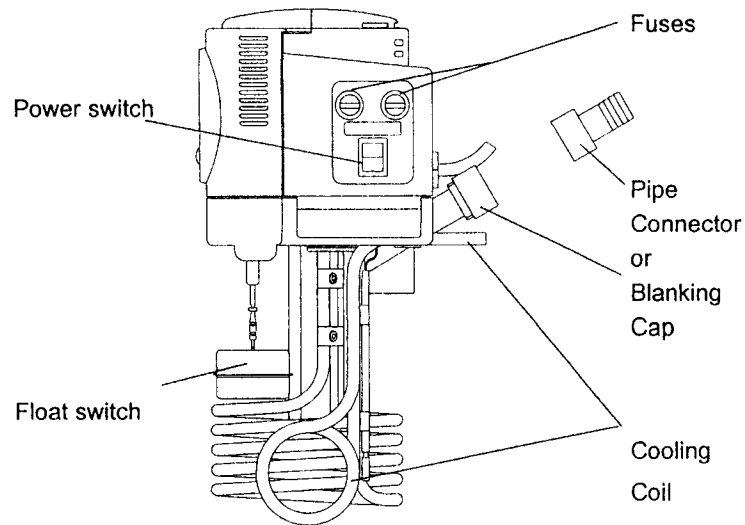

- Switch the unit on by pressing the power switch. The switch and the POWER indicator on the front will light up.

When you Switch On the HCTB-3040

When you first switch on, the display will show the edition of the software which your unit uses. For example software issue "5.37" would be shown as follows:

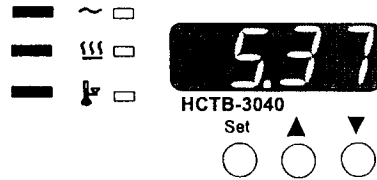

It will display this for 1 second, then the actual temperature of the bath will be indicated.

The Front Panel Controls

The front panel controls consist of three buttons for controlling the display, a four digit LED display and three indicators.

The SET temperature Button

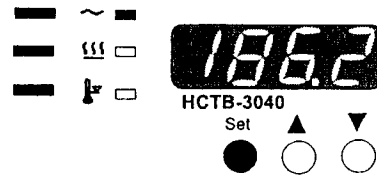

The SET temperature button displays the set temperature when pressed.

The UP ARROW Button

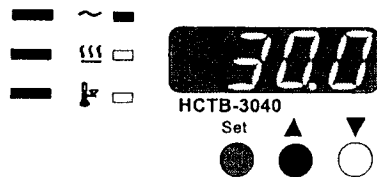

When the SET temperature button is held down and the UP ARROW button is pressed, the set temperature is increased.

The DOWN ARROW Button

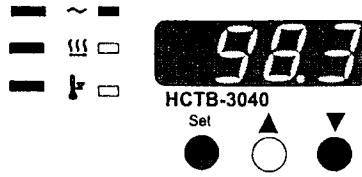

When the **SET** temperature button is held down and the **DOWN ARROW** button is pressed, the set temperature is decreased.

Speed of Change of Set Temperature

Each press of the **UP ARROW** or **DOWN ARROW** buttons will increase or decrease the set temperature by 0.1°C. If the buttons are held down the temperature change will accelerate to 5° per second

Power Indicator

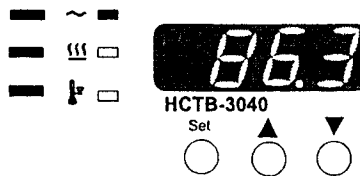

The top indicator shows that there is power to the unit

Heater Indicator

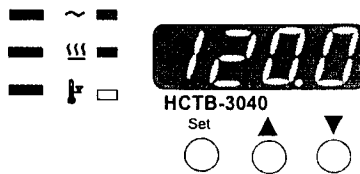

The next indicator shows when the heater is heating. When the temperature is being set, and the new set temperature is higher than the temperature already in the unit, the heater indicator will light as the unit tries to follow the set temperature. If the light is on continuously the heater is getting constant power. The only exception is described under Over-Temperature Indicator. As the temperature approaches the set temperature the heater indicator will flash. When set temperature is reached the indicator will stay on for shorter periods. If the bath temperature is above the set temperature then the indicator will be off, as the heater is not getting any power.

Over-Temperature Indicator

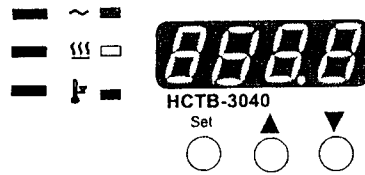

If the unit should, for any reason, exceed the temperature set for the over-temperature cutout, the over-temperature indicator will light. The heater will have been switched off and the unit will begin to cool even if the heater light is on (the light staying on or not depends on which circuit has sensed an over-temperature).

Low Liquid Level

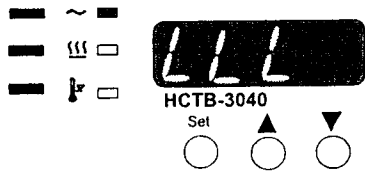

The float switch will trip if the liquid gets below a safe level; the display will change to "LLL". The heater will be switched off. Fill the bath to above the minimum level of 90mm and the display will return to the 'present' temperature; the unit will again work.

Sensor fault Indicator

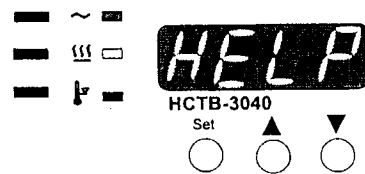

If there should, for any reason, be a sensor fault, the bottom indicator will light. The power to the heater will have been switched off and the unit will begin to return to ambient even if the heater light is on (the light staying on or not depends on which circuit has sensed a fault).

After Use

When you have finished heating samples, remember that parts of the unit and the samples may be very hot. Take the precautions listed earlier. We recommend that the samples should be allowed to cool to 50°C before being removed from the bath. They will still have to be handled with care.

Should you want to remove the unit from the bath, it too should be allowed to cool to 50°C before being removed.

Remember the bridge, the lid (if used), the bath and all other parts close to the bath will be hot while it is in use.

Setting the Overtemperature Cut-out

An adjustable overtemperature cutout is fitted to the HCTB-3040. When the cutout operates, the heater will stop working, the audible alarm will sound and the 'Overtemperature cutout indicator' will illuminate. The pump will continue working.

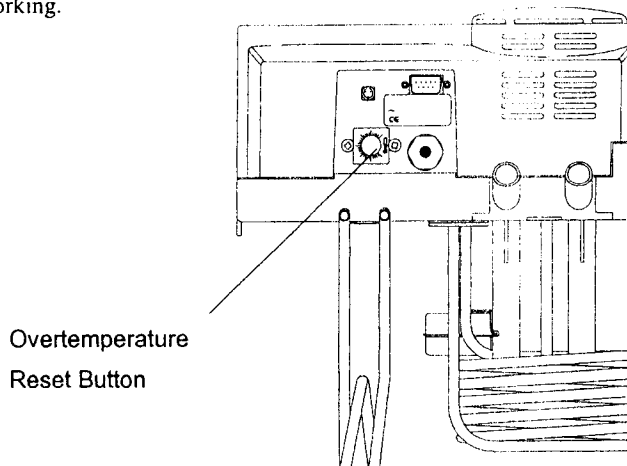

It should be set to approximately 10°C ABOVE THE OPERATING TEMPERATURE. This can be done in one of two ways; '1' is more accurate; '2' is quicker (and better if you do not want to overheat the liquid). For both, first turn the reset button fully clockwise then:

- 1 Heat the bath to the **desired cutout temperature** and turn the reset button anticlockwise until the cutout just trips.

Either: Switch off at the mains power. Remove the unit from the liquid and press the reset button. Return the unit to the liquid, switch on the mains power. The heater will again work.

Or: Allow the liquid to cool, may be as much as 40°C, and press the reset button. The heater will again work.

- 2 Heat the bath to the required **maximum operating temperature** and turn the reset button anticlockwise until the cutout just trips. Turn the reset button clockwise one small division on the label and press the reset button. The heater will again work.

An alarm will sound when the overtemperature cutout is activated by a temperature higher than that set for the overtemperature cutout. Reset the overtemperature cutout, by pressing the reset button, to stop the alarm.

RS232 SERIAL INTERFACE

The HCTB-3040 may send data logging information to an IBM PC or compatible computer by connecting the unit and the PC via an RS232 cable, and installing the "Thermsoft" software. Contact your supplier for details.

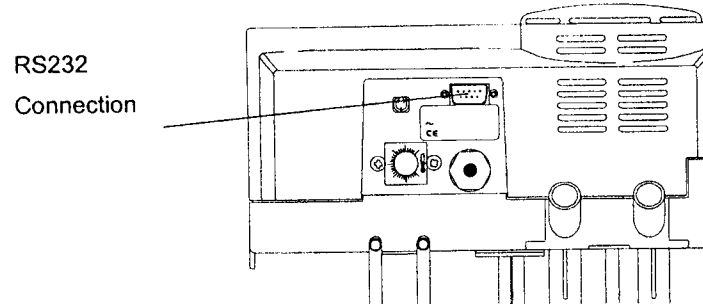

The RS232 cable must be fitted to both the unit and the PC before either unit is powered up, otherwise, data integrity cannot be guaranteed. Once the cable is fitted, it does not matter which unit is powered up first.

The following tables indicate the cable specifications for a 9-way PC serial port:

Thermoregulator		PC	
<i>9-way female D type</i>		<i>9-way female D type</i>	
pin	signal	pin	
Case	F.GND	Case	
3	TxD	3	
2	RxD	2	
7	RTS	7	
8	CTS	8	
6	DSR	6	
1	CD	1	
4	DTR	4	
5	S.GND	5	

Sending data to the PC

The procedure for sending data to the PC is described in the "help" instructions as part of the software. The PC must be properly connected by the RS232 cable and running circulator software to accept or display data.

ADDITIONAL INFORMATION

NOTE THAT THIS EQUIPMENT SHOULD ONLY BE DISMANTLED BY PROPERLY TRAINED PERSONNEL. **REMOVING THE TOP CASE EXPOSES POTENTIALLY LETHAL MAINS VOLTAGE.** THERE ARE NO OPERATOR MAINTAINABLE PARTS WITHIN THE EQUIPMENT.

In the unlikely event that you experience any problems with your Thermoregulator which cannot easily be remedied, you should contact your supplier and return the unit if necessary. Please include any details of the fault observed and remember to return the unit in its original packing. Omega accept no responsibility for damage to units which are not properly packed for shipping: if in doubt, contact your supplier.

Operator maintenance

1. Cleaning

Before cleaning your unit ALWAYS disconnect from the power supply and allow to cool below 50° C.

Your Thermoregulator can be cleaned by wiping with a damp soapy cloth. Care should be exercised to prevent water from running inside the unit. Do not use abrasive cleaners.

2. Overtemperature cut-out

The overtemperature cut-out is a sensitive mechanical device and mechanical shock can cause it to trip.

- In the event of no heater power, check the mains plug and lead, then reset the cut-out control.
- Repeated operation of the cut-out indicates a serious fault: you may need to return the unit to your supplier for repair.

3. Fuses

Your unit is protected by two fuses.

230V 2 x F10A; 120/100V 2 x F16A

These should only be changed by suitably qualified personnel.

If the fuses blow persistently, a serious fault is indicated and you may need to return the unit to your supplier for repair.

Where Do I Find Everything I Need for Process Measurement and Control? OMEGA...Of Course!

TEMPERATURE

- Thermocouple, RTD & Thermistor Probes, Connectors, Panels & Assemblies
- Wire: Thermocouple, RTD & Thermistor
- Calibrators & Ice Point References
- Recorders, Controllers & Process Monitors
- Infrared Pyrometers

PRESSURE, STRAIN AND FORCE

- Transducers & Strain Gauges
- Load Cells & Pressure Gauges
- Displacement Transducers
- Instrumentation & Accessories

FLOW/LEVEL

- Rotameters, Gas Mass Flowmeters & Flow Computers
- Air Velocity Indicators
- Turbine/Paddlewheel Systems
- Totalizers & Batch Controllers

pH/CONDUCTIVITY

- pH Electrodes, Testers & Accessories
- Benchtop/Laboratory Meters
- Controllers, Calibrators, Simulators & Pumps
- Industrial pH & Conductivity Equipment

DATA ACQUISITION

- Data Acquisition & Engineering Software
- Communications-Based Acquisition Systems
- Plug-in Cards for Apple, IBM & Compatibles
- Datalogging Systems
- Recorders, Printers & Plotters

HEATERS

- Heating Cable
- Cartridge & Strip Heaters
- Immersion & Band Heaters
- Flexible Heaters
- Laboratory Heaters

ENVIRONMENTAL MONITORING AND CONTROL

- Metering & Control Instrumentation
- Refractometers
- Pumps & Tubing
- Air, Soil & Water Monitors
- Industrial Water & Wastewater Treatment
- pH, Conductivity & Dissolved Oxygen Instruments



WARRANTY/DISCLAIMER

OMEGA ENGINEERING, INC. warrants this unit to be free of defects in materials and workmanship for a period of **13 months** from date of purchase. OMEGA Warranty adds an additional one (1) month grace period to the normal **one (1) year product warranty** to cover handling and shipping time. This ensures that OMEGA's customers receive maximum coverage on each product.

If the unit should malfunction, it must be returned to the factory for evaluation. OMEGA's Customer Service Department will issue an Authorized Return (AR) number immediately upon phone or written request. Upon examination by OMEGA, if the unit is found to be defective it will be repaired or replaced at no charge. OMEGA's WARRANTY does not apply to defects resulting from any action of the purchaser, including but not limited to mishandling, improper interfacing, operation outside of design limits, improper repair, or unauthorized modification. This WARRANTY is VOID if the unit shows evidence of having been tampered with or shows evidence of being damaged as a result of excessive corrosion; or current, heat, moisture or vibration; improper specification; misapplication; misuse or other operating conditions outside of OMEGA's control. Components which wear are not warranted, including but not limited to contact points, fuses, and triacs.

OMEGA is pleased to offer suggestions on the use of its various products. However, OMEGA neither assumes responsibility for any omissions or errors nor assumes liability for any damages that result from the use of its products in accordance with information provided by OMEGA, either verbal or written. OMEGA warrants only that the parts manufactured by it will be as specified and free of defects. OMEGA MAKES NO OTHER WARRANTIES OR REPRESENTATIONS OF ANY KIND WHATSOEVER, EXPRESSED OR IMPLIED, EXCEPT THAT OF TITLE, AND ALL IMPLIED WARRANTIES INCLUDING ANY WARRANTY OF MERCHANTABILITY AND FITNESS FOR A PARTICULAR PURPOSE ARE HEREBY DISCLAIMED. LIMITATION OF LIABILITY: The remedies of purchaser set forth herein are exclusive and the total liability of OMEGA with respect to this order, whether based on contract, warranty, negligence, indemnification, strict liability or otherwise, shall not exceed the purchase price of the component upon which liability is based. In no event shall OMEGA be liable for consequential, incidental or special damages.

CONDITIONS: Equipment sold by OMEGA is not intended to be used, nor shall it be used: (1) as a "Basic Component" under 10 CFR 21 (NRC), used in or with any nuclear installation or activity; or (2) in medical applications or used on humans. Should any Product(s) be used in or with any nuclear installation or activity, medical application, used on humans, or misused in any way, OMEGA assumes no responsibility as set forth in our basic WARRANTY/DISCLAIMER language, and additionally, purchaser will indemnify OMEGA and hold OMEGA harmless from any liability or damage whatsoever arising out of the use of the Product(s) in such a manner.

RETURN REQUESTS / INQUIRIES

Direct all warranty and repair requests/inquiries to the OMEGA Customer Service Department. BEFORE RETURNING ANY PRODUCT(S) TO OMEGA, PURCHASER MUST OBTAIN AN AUTHORIZED RETURN (AR) NUMBER FROM OMEGA'S CUSTOMER SERVICE DEPARTMENT (IN ORDER TO AVOID PROCESSING DELAYS). The assigned AR number should then be marked on the outside of the return package and on any correspondence.

The purchaser is responsible for shipping charges, freight, insurance and proper packaging to prevent breakage in transit.

FOR **WARRANTY** RETURNS, please have the following information available BEFORE contacting OMEGA:

1. P.O. number under which the product was PURCHASED,
2. Model and serial number of the product under warranty, and
3. Repair instructions and/or specific problems relative to the product.

FOR **NON-WARRANTY** REPAIRS, consult OMEGA for current repair charges. Have the following information available BEFORE contacting OMEGA:

1. P.O. number to cover the COST of the repair,
2. Model and serial number of product, and
3. Repair instructions and/or specific problems relative to the product.

OMEGA's policy is to make running changes, not model changes, whenever an improvement is possible. This affords our customers the latest in technology and engineering.

OMEGA is a registered trademark of OMEGA ENGINEERING, INC.

© Copyright 1996 OMEGA ENGINEERING, INC. All rights reserved. This document may not be copied, photocopied, reproduced, translated, or reduced to any electronic medium or machine-readable form, in whole or in part, without prior written consent of OMEGA ENGINEERING, INC.